

5 3001 SHORE A

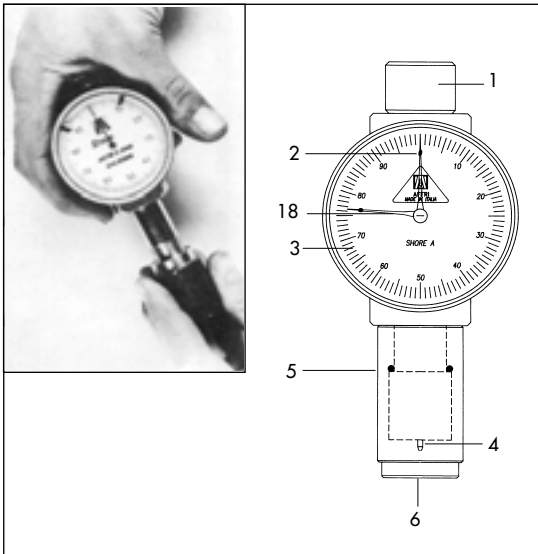

3001 Shore A hardness tester carries out the tests using the original Shore system on soft plastics and rubber and materials with hardness between 0 and 100 points of the Shore A Scale according to the DIN 53505 and ASTM D 2240 - ISO R.868 - JIS K7215 specifications. The thickness of the test sample must be equal to or higher than 6 mm and it is possible for more layers to overlap. For the test, lay the test sample perpendicular to a hard surface.

How to use the (manual) hardness tester

1. Before starting the test you need to remove the cover (5) protecting the penetrator (4).
2. Hold the hardness tester as shown in the picture and push it perpendicularly on the test sample.
3. The pointer (2) or (18) will show the hardness value on the scale. The reading can be made immediately or after 5 seconds.
4. To check the status of the penetrator (4), press the metallic ring of the cover (5) on the penetrator; when the two touch, the pointer must show the value 0 with a tolerance of ± 1 .

Shore A hardness tester can carry lab tests too using the specific stand; to dock the hardness tester, remove the cap (1). See box 9.

Maintenance

Shore A hardness tester does not require any special care; you should, however, clean the penetrator and the brass surface with a cloth before starting the test. Use it carefully. After using it, put it back in its case.

- The hardness tester should be certified every 6 or 12 months by our calibration centre.

Accessory (18) pointer for maximum value

On request, you can have a double pointer to show the maximum value (Art.18). Return the pointer for maximum value to 0 each time you take a measurement.

6 3002 SHORE D

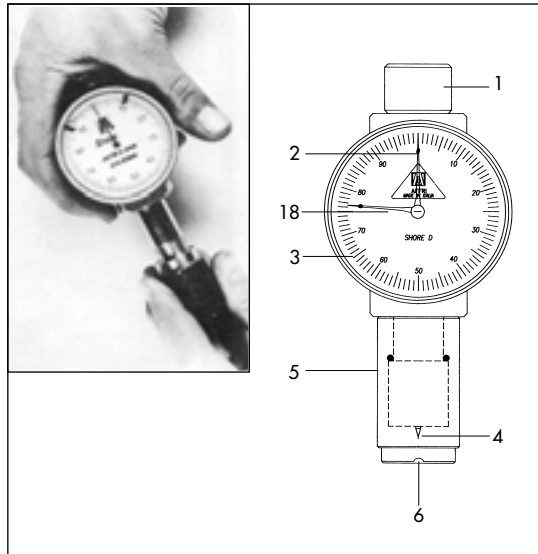

3002 Shore D hardness tester carries out hardness tests using the original Shore system on plastic materials with hardness between 0 and 100 of the Shore D scale according to DIN 53505 and ASTM D 2240 - ISO R.868 - JIS K7215 specifications.

How to use the (manual) hardness tester

1. Before starting the test you need to remove the cover (5) protecting the penetrator (4).
2. Hold the hardness tester as shown in the picture and push it on the test sample; the pointer (2) or (18) will show the hardness value on the scale.
3. To test the status of the penetrator (4) press the metallic ring of the cover (5) against the penetrator so that the penetrator and the hole of the ring are aligned; when the two touch, the pointer must display 50 on the scale.

Shore D hardness tester can also carry out lab tests using the specific stand; to dock the hardness tester remove the cap (1). See box 9.

Maintenance

Shore D hardness tester doesn't require any special care; you should, however, clean the penetrator and the brass surface with a cloth before starting the test. Use it carefully. After using it, put it back in its case.

- The hardness tester should be certified every 6 or 12 months by our calibration centre.

Accessory (18) pointer for maximum value

On request, you can have a double pointer to show the maximum values (art.18). Return the pointer for maximum value to 0 each time you take a measurement.

7 3003 SHORE A (with presser)

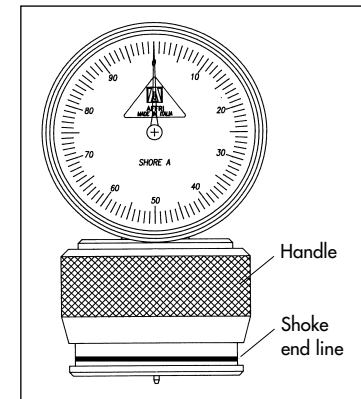

3003 Shore A hardness tester carries out the test using the original Shore method on plastics material (specifically designed for gummed cylinders) with hardness between 0 and 100 points of the Shore A scale according to DIN 53505 and ASTM D 2240 - ISO R.868 - JIS K7215 specifications.

How to use the hardness tester

3003 hardness tester includes a large base and a spring handle.

1. Hold the hardness tester on the knurled side and press it on the surface to test.
2. When the knurled handle comes to coincide with the end line notch, hold it in this position and read the value on the scale.
3. Decrease the pressure on the handle. The hardness tester is ready for a new test.

Calibration test

1. Check to see that the base of the hardness tester isn't dented in any way.
2. Press the hardness tester on a glass plate.
3. The pointer must display 100 ± 1 . Otherwise, send the hardness tester back to the manufacturer.

Maintenance

Shore A hardness tester doesn't require special care; you should, however, clean it and the surface with a cloth before starting the test. Use it carefully.

- The hardness tester should be certified every 6 or 12 months by our calibration centre.

8 DIGITAL 3011 SHORE A And DIGITAL 3012 SHORE D

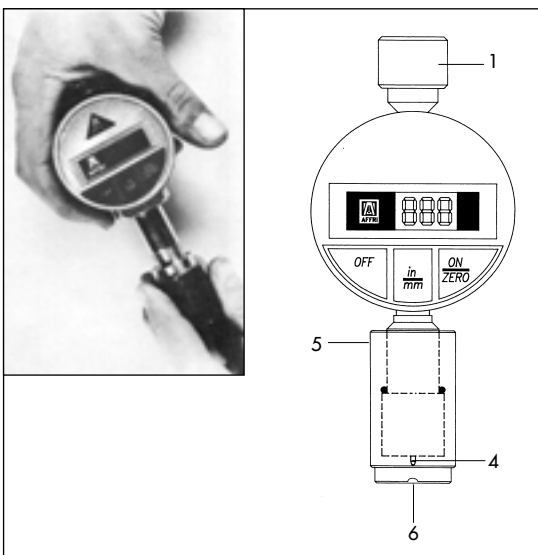

- The digimatic data output allows the sending of the results to a printer to get a print out the measurement
- It can be used in any position and angle.

Switching on

Press the ON button, you should see 000,0; if you see --- it means that the battery is expired; if you see 00.0 you need to press twice the middle button.

Switching off

Press the OFF button.

Changing the battery

Remove the small cap on the circumference of the hardness tester, take out the battery case and substitute the lithium battery with an identical one (like the ones used for watches not in the Italian text). Check its polarity and reinsert the cap.

How to use the hardness tester

1. Before starting the test, remove the coverage (5) protecting the penetrator (4).
2. Hold the hardness tester and press it perpendicularly on the test sample.
3. On the display you'll see the hardness value. The reading can be made immediately or after 5 seconds.
4. To check the status of the penetrator (4) press the metallic ring on the cover (5) on the penetrator and when the two touch, the pointer must be on 0 with +1 tolerance.

Shore A hardness tester can also carry out lab tests using the specific stand; to dock the hardness tester, remove the cap (1). See Options in box 9.

AFFRI Digital 3011 Shore A or 3102 Shore D hardness tester has been designed and passed high-precision tests on products of any shape and size according to DIN 53505 and ASTM D 2240 - ISO R.868 - JIS K7215 specifications.

Features

- The hardness tester includes crystal liquid (LCD) reading and it is powered by a long lasting lithium battery.
- The minimum reading differentiation is 0.5 Shore; the scale ranges from 0 to 100 shore units.

Maintenance

Shore A hardness tester does not require any special care; you should, however, clean the penetrator and the brass surface with a cloth before starting the test. Use it carefully. After using it put it in its case.

- The hardness tester should be certified every 6 or 12 months by our calibration centre.

Connecting to a printer

Remove the rubber cap on the top side in front of the battery case. Connect the cable, supplied on request, specifically designed for AFFRI hardness tester and specific printer.

9 OPTIONS - ASTM D 2240-75 - DIN 53505

Art.13 - Stand for lab test for both analog and digital shore A and D units. It is supplied with calibrated mass for tests on A units.

Art.14 - Additional mass for Shore C - D - DO.

Art.16 - Set of accessories allowing to test O-Rings with the unified measures according to the test mode shown by the ASTM 1414 specifications; they are supplied with art.13 stand.

Setting up the art. 13 stand

Insert the bar with arm in the hole of the base for about 7/8 cm as shown in the picture.

Lock the δ MA grub screw on the back of the base with an 3 mm-hexagonal wrench; screw it up to the end. The base is now complete.

Aligning the hardness tester

Remove the screw cap at the top of the hardness tester. Screw the hardness tester in the specific knurled surface of the support and lock it; put the metal-

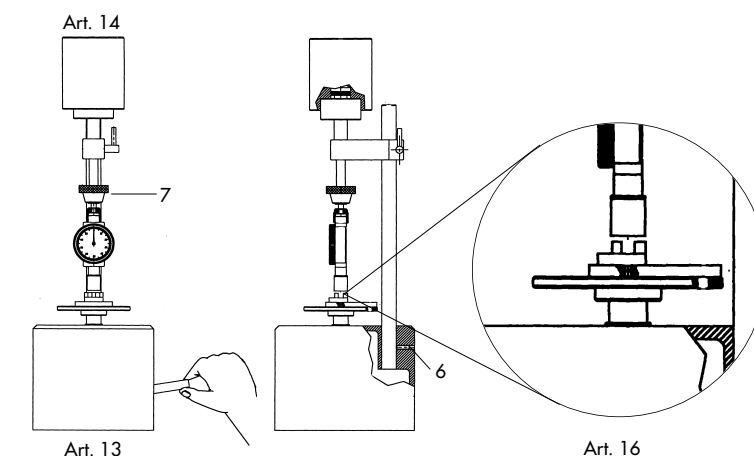

lic ring (supplied with the stand) on the chromate surface of the stand. Adjust the height of the hardness tester arm so that the point of the hardness tester and the metallic ring get closer, make the hole of the ring correspond to the hardness tester point, push down the command lever until the chromate plate raises the hardness tester. In this position, move the hardness tester laterally so that its base and that of the metallic ring are aligned. Screw in the knurled ring to lock the hinge. Push down the surface, take the hardness tester away and remove the metallic ring. The hardness tester is now aligned and ready for use.

Using the stand with Shore A hardness tester

Put the test sample onto the appropriate surface, adjust the height of the arm to move the hardness tester closer to the test sample. Push down the lever until the hardness tester is raised and read the hardness value.

Using the stand with Shore D hardness tester

Apply the additional mass of 4 Kg (art.14) at the top of the stand. Carry out the test as with Shore A hardness tester.

Tests on OR ring

To carry out the tests on OR, the holding surface for the test sample must include two centring holes. Fix the plate holding the centring device onto the surface of the stand (art.16), insert the centring device corresponding to the diameter of the OR chord to be tested (the diameter is printed on the centring device) in the hole of the plate; insert the OR, in this way the OR chord remains aligned with the penetrator of the hardness tester; carry out the hardness test Shore A according to ASTM D 1414 specifications. In some cases, use two or more ORs on top of each other.

Precautions and maintenance

Do not carry out tests on the surface designed to hold the pieces. Clean the surface and the point of the hardness tester with alcohol and lubricate with fluid oil.

WARNING: the minimum thickness of the sample to be tested should not be less than 6 mms. If necessary, put more layers of material until this thickness is reached.

Contents

- Lab and portable hardness tester Usage and models 3
- Options Hardness scale 4
- 3001 SHORE A 5
- 3001 SHORE D 6
- 3003 SHORE A (with presser) 7
- 3011 Digital SHORE A And 3012 SHORE 8
- Options - ASTM D 2240-75 - DIN 53505 9
- Calibration diagram Shore A 10
- Calibration diagram Shore D 11

Copyright O.M.A.G. 1999

OMAG believes that the following instructions are accurate and reliable. OMAG cannot be held liable for damages incurred by using these instructions.

OMAG has the copyright of all the information in this manual. No printing, either total or partial, can be made without the written authorisation of OMAG.

This information is subject to change without notice. OMAG has the right to modify the specifications of its products without notice.

LAB AND PORTABLE HARDNESS TESTER

It complies with ASTM D 2240, ISO R.868, DIN 53505, JIS K7215 standards for rubber, plastics, medical products, paper, sponge according to A, B, C, D, O, and OO methods.

USAGE AND MODELS

The hardness tester can be used for tyres, medical products, packing, packages, gummed roller for calendaring, cardboard, wood, toys, tool grips, handles for household articles, car parts, and plastic plates.

- 3001 Shore A** For rubber, pliable plastics, PVC, polyester, paper, cardboard, etc.
- 3002 Shore D** For rigid and hard materials, synthetic and acrylic materials, plexiglas, wood, derling, nylon, etc.
- 3004 Shore C** As D for low values
- 3008 Shore OO** For sponge, natural rubber, silicon
- 3009 Shore O** As Scale A for low values
- 3010 Shore DO** As B and C
- 3011 Shore B** As Scale A for high value
- 3003 Shore A** Portable, easy to use with a constant pressure system integrated on the large support base, it is very precise in the lab, even with curved surfaces. It is a good choice for testing tyres, gummed rollers, and rolls of paper.
- 3101 Shore A** Digital, it includes data output for SPC and data printing capabilities.
- 3102 Shore D** Digital, it includes data output for SPC and data printing capabilities.

OPTIONS

- Art.13** Stand for lab test on both analog and digital Shore A and D models. It comes supplied with mass calibration for tests on A units.
- Art.14** Additional mass for Shore C - D - DO.
- Art.16** Set of accessories for testing on O-Rings in the unified measures according to the test mode supported by ASTM 1414 specifications; they are included in the Art.13 stand.

HARDNESS SCALE

	Hardness values									
	soft ----- hard									
A	10	20	30	40	50	60	70	80	90	100
B	10	20	30	40	50	60	70	80	90	100
C	10	20	30	40	50	60	70	80	90	100
D	10	20	30	40	50	60	70	80	90	100
DO	10	20	30	40	50	60	70	80	90	100
O	10	20	30	40	50	60	70	80	90	100
OO	10	20	30	40	50	60	70	80	90	100

Distribution of the individual scale (not to be used as a conversion table).

ENGLISH

10 CALIBRATION DIAGRAM SHORE A

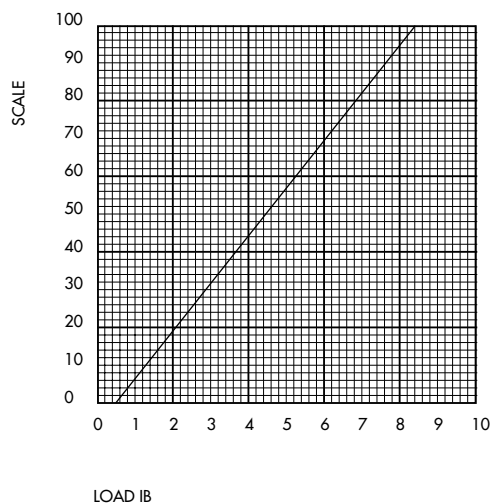

11 CALIBRATION DIAGRAM SHORE D

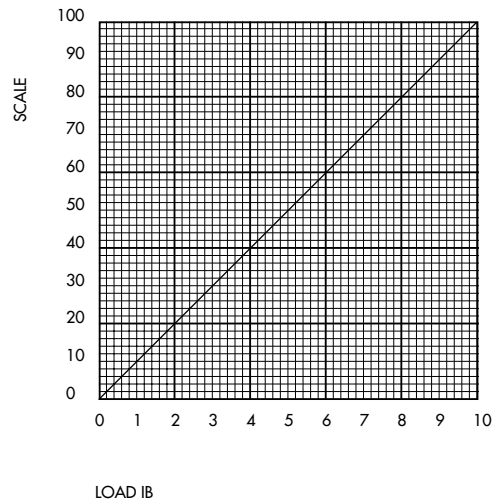

SHORE LAB AND PORTABLE HARDNESS TESTER
IT MATCHES THE
ASTM D 2240 - ISO R.868
DIN 53505 - JIS K7215 STANDARD

INSTRUCTION'S MANUAL



SERIAL No
CHECK

SERIAL No
CHECK

O.M.A.G. Costruzione apparecchiature di misura
Via M. Tagliferro, 8
21056 INDUNO OLONA - VARESE - ITALY
Tel. 0039 / 0332 200546

Distributore unico AFFRI COMMERCIALE
Via M. Tagliferro, 8
21056 INDUNO OLONA - VARESE - ITALY
Tel. 0039 / 0332 201533
Fax 0039 / 0332 203621

